



## LED DISPLAY DRIVER

### FEATURES SUMMARY

- 2 DIGIT LED DRIVER (15 segments)
- CURRENT GENERATOR OUTPUTS (no resistor required)
- CONTINUOUS BRIGHTNESS CONTROL
- SERIAL DATA INPUT
- WIDE SUPPLY VOLTAGE OPERATION
- TTL COMPATIBILITY

### APPLICATION EXAMPLES

- MICROPROCESSOR DISPLAYS
- INDUSTRIAL CONTROL INDICATOR
- RELAY DRIVER
- INSTRUMENTATION READOUTS

### DESCRIPTION

The M5482 is a monolithic MOS integrated circuit produced with an N-channel silicon gate technology. It utilizes the M5451 die packaged in a 20-pin plastic package copper frame, making it ideal for a 2-digit display. A single pin controls the LED dis-

play brightness by setting a reference current through a variable resistor connected either to VDD or to a separate supply of 13.2V maximum.

Figure 1. Package

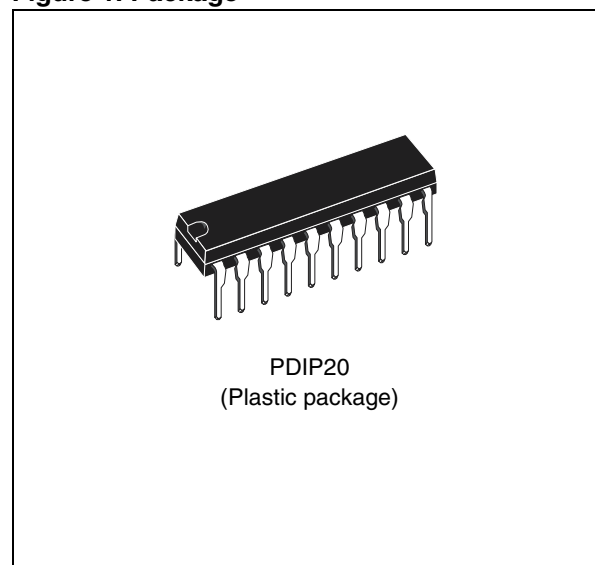

Figure 2. Pin Connections

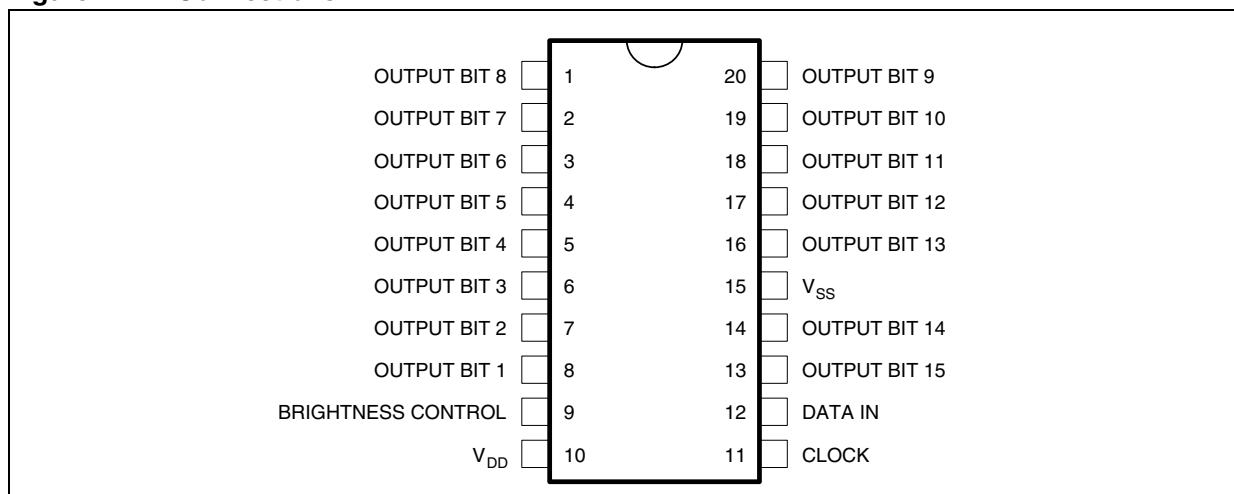

Figure 3. Block Diagram

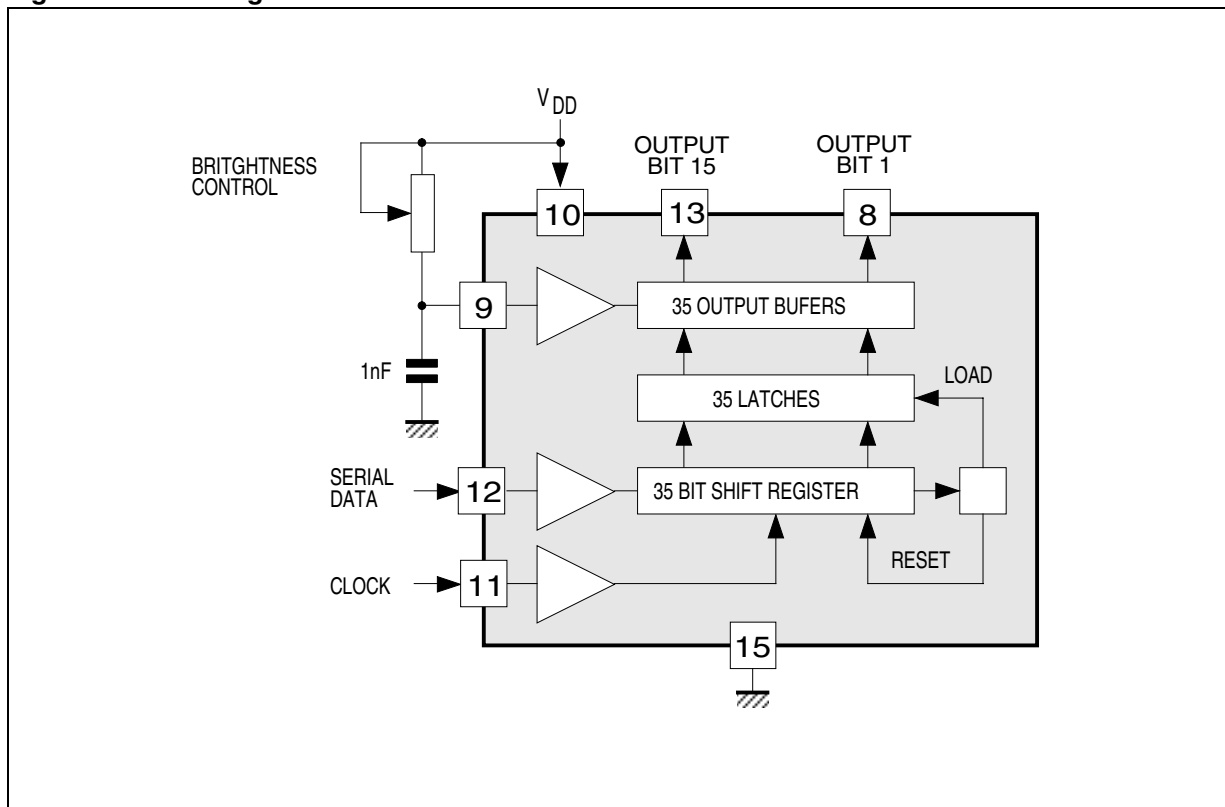

Table 1. Absolute Maximum Ratings

Symbol	Parameter	Value	Unit
$V_{DD}$	Supply Voltage	- 0.3 to 15	V
$V_I$	Input Voltage	- 0.3 to 15	V
$V_{O(off)}$	Off State Output Voltage	15	V
$I_o$	Output Sink Current	40	mA
$P_{TOT}$	Total Package Power Dissipation at 25°C	1.5	W
	Total Package Power Dissipation at 85°C	800	mW
$T_j$	Junction Temperature	150	°C
$T_{OPER}$	Operating Temperature Range	- 25 to 85	°C
$T_{STG}$	Storage Temperature Range	- 65 to 150	°C

Note: Stresses in excess of those listed under "Absolute Maximum Ratings" may cause permanent damage to the device. This is a stress rating only and functional operation of the device at these or any other conditions in excess of those indicated in the operational sections of this specification is not implied. Exposure to absolute maximum rating conditions for extended periods may affect device reliability.

**Table 2. Static Electrical Characteristics**(T<sub>amb</sub> within operating range, V<sub>DD</sub> = 4.75V to 13.2V, V<sub>SS</sub> = 0V, unless otherwise specified)

Symbol	Parameter	Test Conditions	Min.	Typ.	Max.	Unit
V <sub>DD</sub>	Supply Voltage		4.75		13.2	V
I <sub>DD</sub>	Supply Current	V <sub>DD</sub> = 13.2V			7	mA
V <sub>I</sub>	Input Voltage Logical "0" Level Logical "1" Level	± 10μA Input Bias	- 0.3		0.8	V
		4.75 ≤ V <sub>DD</sub> ≤ 5.25	2.2		V <sub>DD</sub>	V
		V <sub>DD</sub> > 5.25	V <sub>DD</sub> - 2		V <sub>DD</sub>	V
I <sub>B</sub>	Brightness Input Current (note 2)		0		0.75	mA
V <sub>B</sub>	Brightness Input Voltage (pin 9)	Input Current = 750μA, T <sub>amb</sub> = 25°C	3		4.3	V
V <sub>O(off)</sub>	Off State Out. Voltage				13.2	V
I <sub>O</sub>	Out. Sink Current (note 3) Segment OFF Segment ON	V <sub>O</sub> = 3V			10	μA
		V <sub>O</sub> = 1V (note 4)				
		Brightness In. = 0μA	0		10	μA
		Brightness In. = 100μA	2	2,7	4	mA
		Brightness In. = 750μA	12	15	25	mA
f <sub>clock</sub>	Input Clock Frequency		0		0.5	MHz
I <sub>O</sub>	Output Matching (note 1)				± 20	%

Note: 1. Output matching is calculated as the percent variation from I<sub>MAX</sub> + I<sub>MIN</sub>/2.

2. With a fixed resistor on the brightness input some variation in brightness will occur from one device to another.

3. Absolute maximum for each output should be limited to 40mA.

4. The V<sub>O</sub> voltage should be regulated by the user.

## FUNCTIONAL DESCRIPTION

The M5482 uses the M5451 die which is packaged to operate 2-digit alphanumeric displays with minimal interface with the display and the data source.

Serial data transfer from the data source to the display driver is accomplished with 2 signals, serial data and clock. Using a format of a leading "1" followed by the 35 data bits allows data transfer without an additional load signal.

The 35 data bits are latched after the 36th bit is complete, thus providing non-multiplexed, direct drive to the display. Outputs change only if the serial data bits differ from the previous time. Display brightness is determined by control of the output current for LED displays. A 1nF capacitor should

be connected to brightness control, Pin 9, to prevent possible oscillations.

A block diagram is shown in Figure 3. The output current is typically 20 times greater than the current into Pin 9, which is set by an external variable resistor.

There is an internal limiting resistor of 400Ω nominal value.

Figure 4 shows the input data format. A start bit of logical "1" precedes the 35 bits of data. At the 36th clock a LOAD signal is generated synchronously with the high state of the clock, which loads the 35 bits of the shift registers into the latches.

Figure 4. Input Data Format

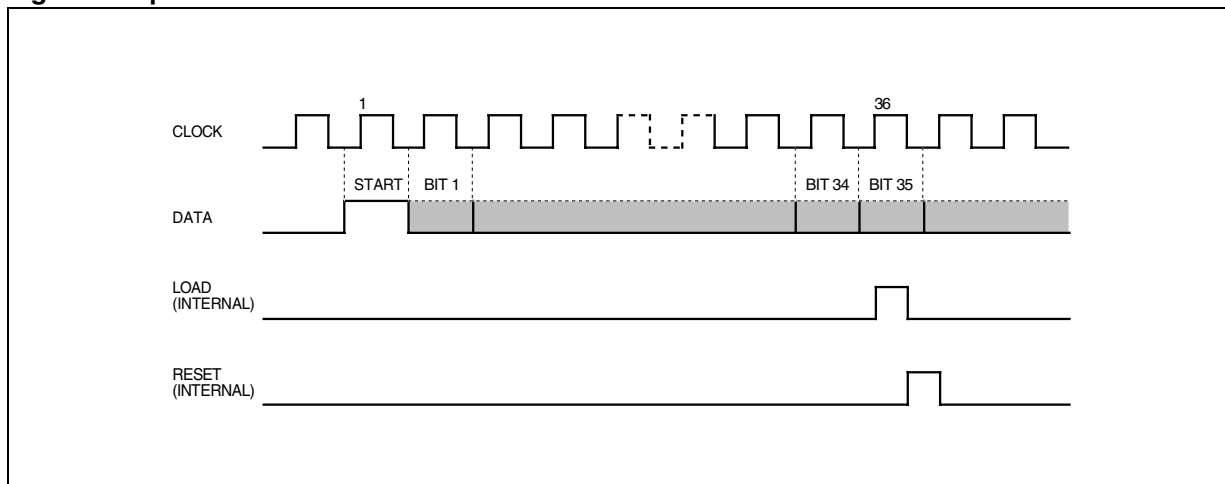

At the low state of the clock a RESET signal is generated which clears all the shift registers for the next set of data. The shift registers are static master slave configurations. There is no clear for the master portion of the first shift register, thus allowing continuous operation.

There must be a complete set of 36 clocks or the shift registers will not clear.

When power is first applied to the chip an internal power ON reset signal is generated which resets all registers and all latches. The START bit and the first clock return the chip to its normal operation.

Figure 5 shows the timing relationships between Data and Clock.

A maximum clock frequency of 0.5 MHz is assumed.

Table 3 shows the Output Data Format for the M5482. Because it uses only 15 of the possible 35 outputs, 20 of the bits are "Don't Cares".

For applications where a lesser number of outputs are used it is possible to either increase the current per output or operate the part at higher than 1V  $V_{OUT}$ .

The following equation can be used for calculations.

$$T_j \dots [(V_{OUT})(I_{LED})(\text{no.of segments}) + V_{DD} \cdot 7 \text{ mA}] (80 \text{ }^\circ\text{C/W}) + T_{\text{amb}}$$

where:

$T_j$  = junction temperature (150 °C max)

$V_{OUT}$  = the voltage at the LED driver outputs

$I_{LED}$  = the LED current

80 °C/W = thermal coefficient of the package

$T_{\text{amb}}$  = ambient temperature

Figure 5.

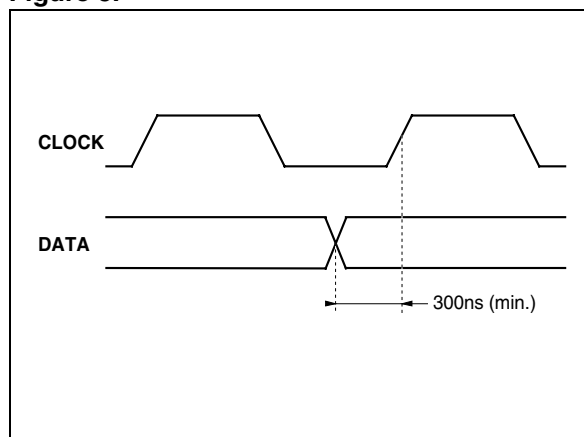
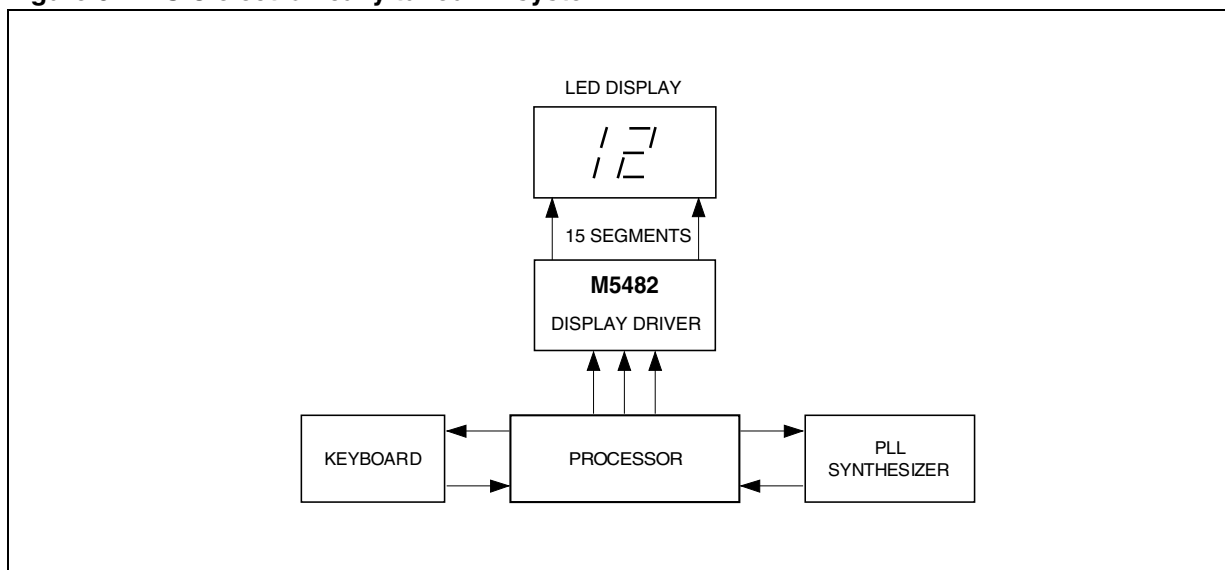

Table 3. Serial Data Bus / Outputs Correspondence

5451	35	34	33	32	31	30	29	28	27	26	25	24	23	22	21	20	19	18	START
5482	15	X	X	X	X	14	13	X	X	X	X	12	11	10	9	X	X	X	START
5451	17	16	15	14	13	12	11	10	9	8	7	6	5	4	3	2	1	START	
5482	X	8	7	6	5	X	X	X	X	4	3	2	1	X	X	X	X	START	

## TYPICAL APPLICATION

Figure 6. BASIC electronically tuned TV system



## POWER DISSIPATION OF THE IC

The power dissipation of the IC can be limited using different configurations.

In this application R must be chosen taking into account the worst operating conditions.

R is determined by the maximum number of segments activated.

Figure 7.

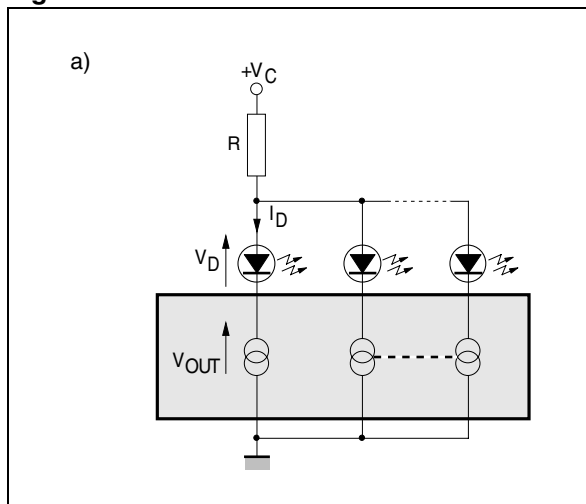

$$R = \frac{V_C - V_{D\text{MAX}} - V_{O\text{MIN}}}{N_{\text{MAX}} I_D}$$

The worst case condition for the device is when roughly half of the maximum number of segments are activated.

It must be checked that the total power dissipation does not exceed the absolute maximum ratings of the device.

In critical cases more resistors can be used in conjunction with groups of segments. In this case the current variation in the single resistor is reduced and  $P_{\text{tot}}$  limited.

Figure 8.

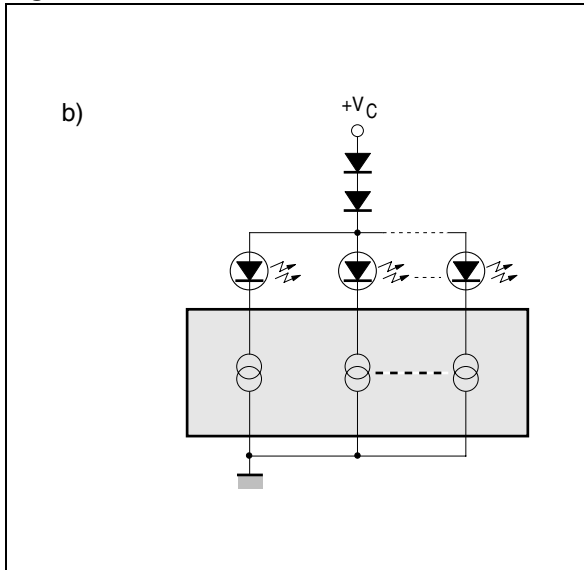

In this configuration the drop on the serial connected diodes is quite stable if the diodes are properly chosen.

The total power dissipation of the IC depends only, in first approximation, on the number of segments activated.

Figure 9.

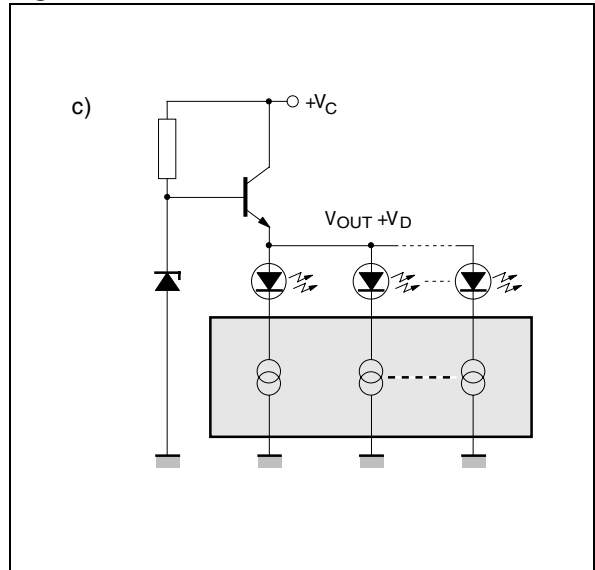

In this configuration  $V_{OUT} + V_D$  is constant. the total power dissipation of the IC depends only on the number of segments activated.

**PART NUMBERING****Table 4. Order Codes**

<b>Part Number</b>	<b>Package</b>	<b>Temperature Range</b>
M5482B7	PDIP20	-25 to 85 °C

PACKAGE MECHANICAL

Table 5. PDIP20 - Mechanical Data

Symbol	millimeters			inches		
	Min	Typ	Max	Min	Typ	Max
a1	0.254			0.010		
B	1.39		1.65	0.055		0.065
b		0.45			0.018	
b1		0.25			0.010	
D			25.4			1.000
E		8.5			0.335	
e		2.54			0.100	
e3		22.86			0.900	
F			7.1			0.280
i			3.93			0.155
L		3.3			0.130	
Z			1.34			0.053

Figure 10. PDIP20 - Package Dimensions

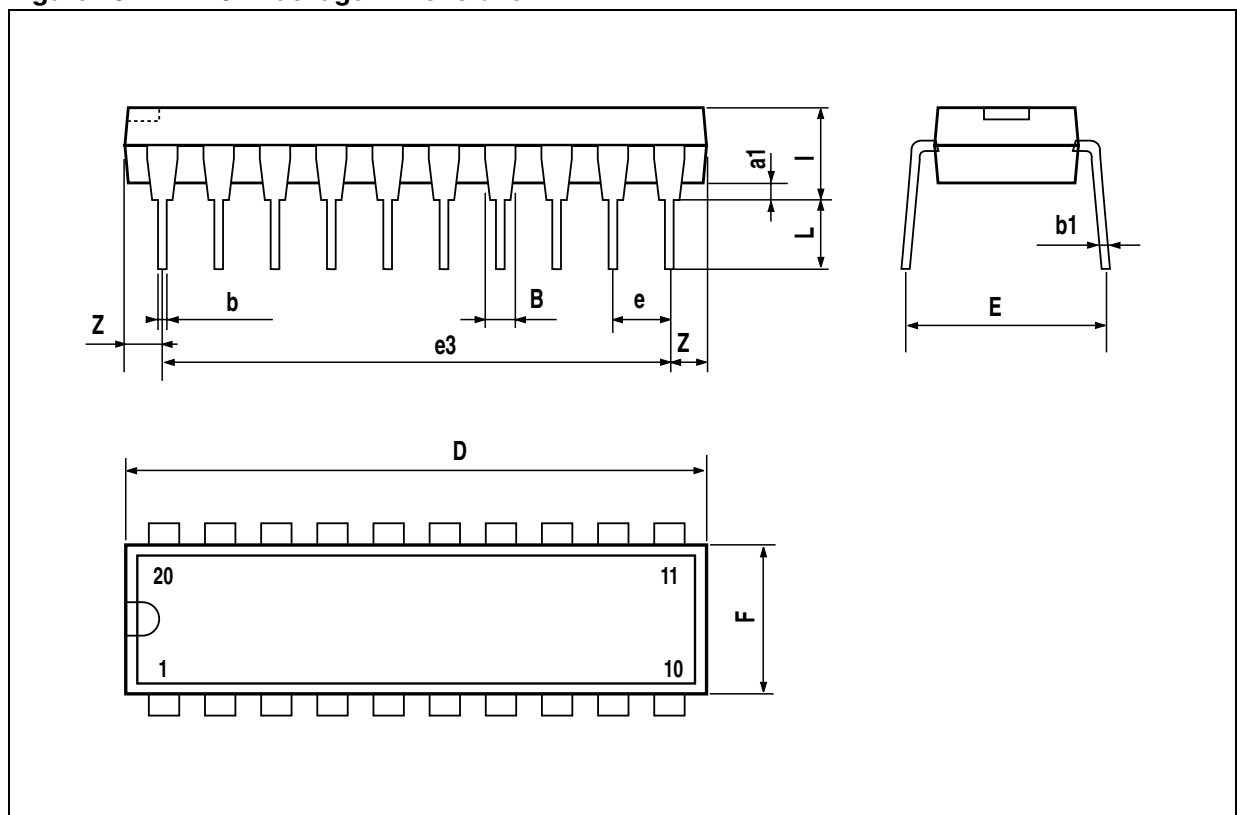

Note: Drawing is not to scale



---

**REVISION HISTORY****Table 6. Revision History**

<b>Date</b>	<b>Revision</b>	<b>Description of Changes</b>
May-1993	1	First Issue
9-June-2004	2	Stylesheet update. No content change.

Information furnished is believed to be accurate and reliable. However, STMicroelectronics assumes no responsibility for the consequences of use of such information nor for any infringement of patents or other rights of third parties which may result from its use. No license is granted by implication or otherwise under any patent or patent rights of STMicroelectronics. Specifications mentioned in this publication are subject to change without notice. This publication supersedes and replaces all information previously supplied. STMicroelectronics products are not authorized for use as critical components in life support devices or systems without express written approval of STMicroelectronics.

The ST logo is a registered trademark of STMicroelectronics.  
All other names are the property of their respective owners

© 2004 STMicroelectronics - All rights reserved

STMicroelectronics GROUP OF COMPANIES

Australia - Belgium - Brazil - Canada - China - Czech Republic - Finland - France - Germany - Hong Kong - India - Israel - Italy - Japan -  
Malaysia - Malta - Morocco - Singapore - Spain - Sweden - Switzerland - United Kingdom - United States

[www.st.com](http://www.st.com)